



## **Rogue Engineering S65 E90/92 M3 Power Pulley Kit Installation Directions Fits 2008 6-speed Manual Only (not DCT)**

Thank you for purchasing the Rogue Engineering S65 V8 E90/92 M3 Power Pulley Kit. Please seek professional help for installation if you are unsure about the procedure listed below.

### **Included Parts**

- o Rogue Engineering Power Pulley (replacement crank pulley)
- o Replacement Belt, 6PK1432 (for water pump, alternator)
- o Replacement Belt, 6PK1033 (for power steering, A/C)

### **Recommended Tools**

- o Metric sockets and ratchet
- o Torx bits
- o Panel popper (to remove plastic expansion rivets)
- o Small flat bladed screwdriver

### **Installation Notes**

1. Start by removing the air intake duct expansion rivets (#1) and torx screws (#2). Remove intake duct (#3 and #4).

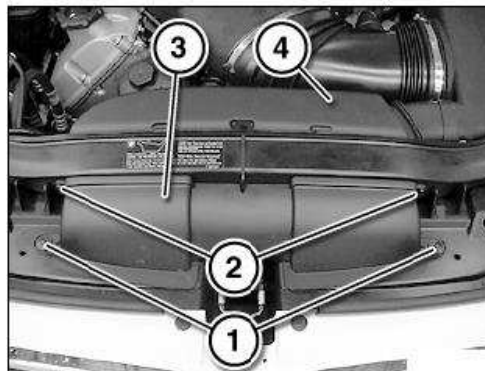

Remove factory airbox (two 10mm bolts hold it down, hose clamp attaches to box).



2. Unclip coolant lines from the lower part of the fan assembly.
3. Unclip connector from fan assembly (black arrow).

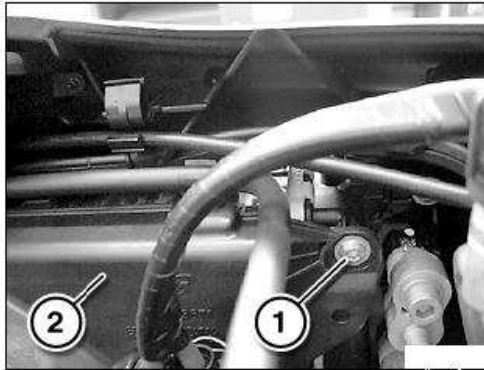
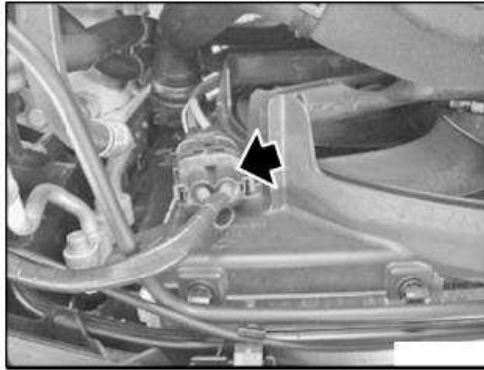

Remove torx (#1) for fan assembly. This is the ONLY screw holding the fan assembly in place.

Unclip all vent lines on the top of the fan assembly. Remove fan assembly upwards (coolant hose may be interfere, just compress out of the way).

4. Remove A/C compressor drive belt. Remove cover from tensioner (#1) and press down to release tension on belt. Remove belt. **The picture below shows the belt routing for the 08 6-speed version. The 08 DCT/all 09 has a different routing.**



5. Remove alternator belt. Start by loosening all four (4) bolts of the water pump. Remove cover from tensioner (#1) and turn clockwise. Remove belt. You may now find it necessary to remove the water pump in order to gain clearance to take the belt off completely.

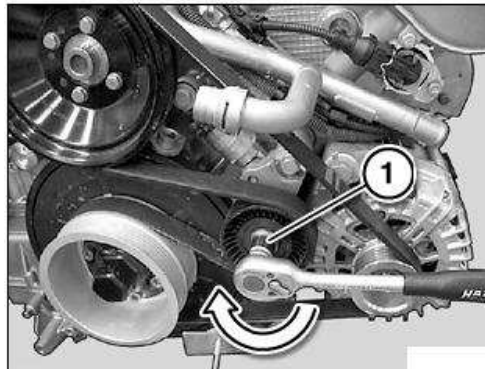



6. Remove the six (6) T45 torx bolts holding on the factory crank pulley (#1). **THESE BOLTS WILL BE REUSED!** Remove cover (#2). **THIS COVER WILL BE REUSED!** Remove stock crank pulley (#3).

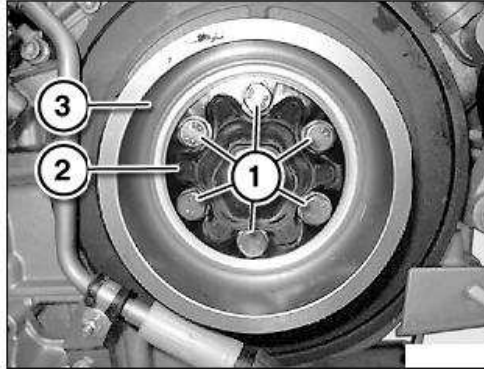

7. Now that you've removed the stock crank pulley, you can begin by installing the Rogue Engineering Power Pulley. Install the cover and stock bolts as well. Torque down.
8. Since the water pump pulley has been previously removed already, start with the 6PK1432 belt and begin installation of the alternator belt. Once you have the belt squeezed back into place, reinstall the water pump pulley. You are now ready to finish installation of the alternator belt.
9. Reinstall A/C belt with supplied 6PK1033 or 6PK1062 (if your car came with double-ribbed belt from the factory). **Please note your production date and which belt you used and contact Rogue Engineering with this information at 201-444-8150!**
10. Reassemble fan assembly and reconnect electrical connector. Reattach lower hoses onto fan assembly.
11. Reinstall airbox and intake ducts. You are now complete! Start engine, check to make sure everything runs properly and smoothly. Enjoy your increased power!